

REAL-TIME MEASUREMENT OF FRESH CONCRETE CONSISTENCY DURING TRANSPORT – PRACTICAL SYSTEM TEST

HARALD GARRECHT, ANDREAS KARDEN, VIKTÓRIA MALÁRICS

Abstract

This paper outlines findings and results obtained by investigating the system Verifi and evaluating its possibility to determine fresh concrete parameters of normal strength concrete in ready mix trucks. The system Verifi measures and documents the consistency of fresh concrete in form of flow table or slump test results for the duration of a delivery cycle. For the investigation two trucks were equipped with the system and tests were performed under realistic conditions. With regard to a practical applicability of the system in Germany the analysis of this study shows positive results. However, the system calibration has been identified as a significant factor relating to the determined parameters, dependent on the vehicle and mixing drum setup type of the ready mix truck. The project was funded by the Forschungsgemeinschaft Transportbeton e. V. (FTB) and was carried out by the Chair of Building Materials, Building Physics and Building Chemistry of the Technische Universität Darmstadt.

Keywords

Real-time measurement, ready mix truck, performance testing, fresh concrete consistency, flow table test, rheology, Bingham parameters

Biographical notes

Prof. Dr.-Ing. Harald Garrecht: 2006-2012 professor at the Chair of Building Materials, Building Physics and Building Chemistry at the Technische Universität Darmstadt; since April 2012 professor at the University of Stuttgart and director of the Institut für Werkstoffe im Bauwesen (IWB) and the Material Testing Institute University of Stuttgart (MPA Stuttgart, Otto-Graf-Institut)

Dipl.-Ing. (FH) Andreas Karden MBA BEng: 2010-2012 research assistant at the Chair of Building Materials, Building Physics and Building Chemistry at the Technische Universität Darmstadt; since May 2012 research assistant at the Institut für Werkstoffe im Bauwesen (IWB) at the University of Stuttgart

Dr.-Ing. Viktória Malárics: 2010-2012 senior research assistant at the Chair of Building Materials, Building Physics and Building Chemistry at the Technische Universität Darmstadt; since May 2012 senior research assistant at the Institut für Werkstoffe im Bauwesen (IWB) at the University of Stuttgart

1. INTRODUCTION

Concrete technological developments result in improved workability, higher strength and durability of concrete. This enables new applications for cement-based materials. In particular, sophisticated special concretes require on the production process aligned developments or rather optimisations of the machinery and plant equipment. An implementation of measurement, process and control concepts is thereby conducive. Moreover, a continuous and necessary monitoring concept which covers the process chain – from production to placement of concrete – is also required to control and evaluate defined properties of concrete. Besides securing and improving product quality, requirements of a quality management system can also be met, as well as optimising ecological and economic indicators, even in the case of normal strength concrete. Consequently, technological developments are desirable. However they must be verified prior market launch, taking into account applicable regulations, as well as a subsequent validation in practice.

2. SYSTEM VERIFI

The system Verifi was developed in the United States. It can determine and document the consistency of fresh concrete during transport in a ready mix truck either as a result of slump or flow table, which is e. g. mainly used in Germany. The system is sold by Grace Construction Products.

2.1 Description of the system

According to the provider of Verifi, the system is suitable for a continuous recording and documenting of the slump and flow table of transported fresh concrete in a ready mix truck. The measuring range is for flow table from 320 to 600 mm and for slump from 0 to 255 mm, whereat the results are displayed in 5 mm steps. The minimum loading volume is 3 m³ concrete for mixing drums with a size of 6 to 8 m³.

The basic elements of the system Verifi and the location of its components on a ready mix truck are schematically shown in Figure 1. Using sensors the torque and the hydraulic pressure of the mixing drum drive mechanism, the drum rotation speed and the direction are determined. The drive capacity and number of revolutions of the mixing drum is used to determine the consistency of fresh concrete and the output of the measured results is carried out directly via a control panel in the cab and on an external display.

Due to the fact, that a subsequent water addition is permitted in the USA¹, the system also has a magnet valve for automatic or manual dosage. The amount of water, which is dosed, is recorded and is therefore traceable.

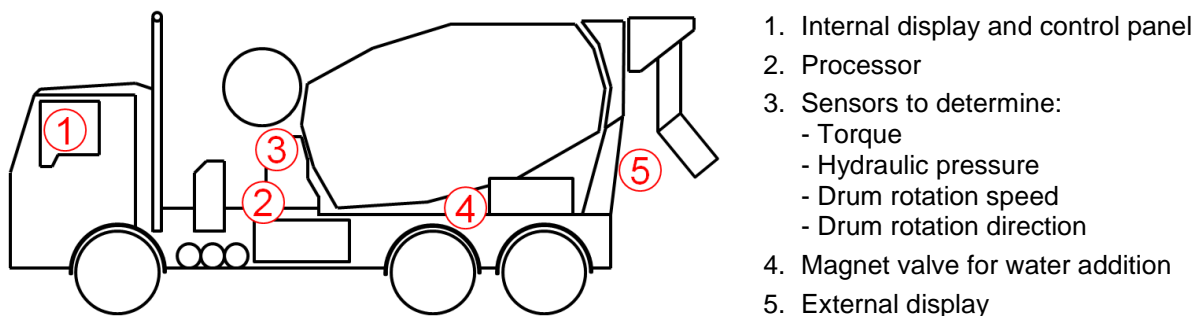

Figure 1: Installation location scheme of system Verifi components on a ready mix truck

¹ Normative situation in Germany: A subsequent addition of water is only allowed if certain conditions according to DIN 1045-2:2008-08 [2] are adhered.

The external display (seven-segments) has a total of ten shortcuts, up to four letters or numbers. Information can be given to the driver, such as the receipt of ordering data. Furthermore, the number of required revolutions of the mixing drum is displayed, which need to be performed directly after the loading of the ready mix truck. Provided that a minimum mixing time is not reached, the system shows a countdown in a seconds frequency to achieve adequate mixing. Furthermore, operations can be specified to the user of the system, such as the adjustment of the mixing drum rotation speed to control the system, since the determination of the consistency can only be performed in a certain speed range. After the process step of the current identification of consistency, the actual flow table result is given out. Furthermore, there is a shortcut for the undercut of the minimum loading volume of 3 m³ of fresh concrete. As a result, the system does not determine any further values.

An additional component of the system Verifi is a radio gateway, installed at the concrete plant. While a ready mix truck arrives the tuning range, the collected data is automatically submitted from the truck via the radio gateway to the USA for evaluation purposes. The prepared data is sent back by e-mail to the ready mix concrete companies in form of tables, including details of sequential arrangement, such as loading or unloading time.

2.2 Calibration of the system

Following the installation of the components, the manufacturer calibrates the system on the ready mix truck. In order to check the complete measuring range of the system, the ready mix truck is loaded with a plastic (F2) till soft (F3) normal weight concrete. The consistency is then changed in steps with water to a flowable consistency of the concrete, after each sampling and testing cycle. The use of a retarder enables a delay of the cement hydration for the required period of adjusting the system settings, if necessary. Before each stepwise change of concrete consistency, samplings are unloaded to determine the flow table in accordance to DIN EN 12350-5:2009-08 [1], provided that this is the decisive parameter during the subsequent operation of the ready mix truck. The direct comparison between the normative determined results and the values identified by the system Verifi results in a calibration curve, which is then implemented into the process computer.

3. METHODOLOGY AND REQUIREMENTS

Subject of the project, presented with essential results within this article, was to evaluate the system Verifi for determining the flow table parameter of normal strength concrete in terms of practical applicability and adequacy. Therefore, two ready mix trucks (A and B) of different vehicle and mixing drum setup types were equipped with the system. For the purpose of the investigations the ready mix trucks were loaded on six consecutive working days with three different concretes (Table 1) and a respective volume of 6 m³ concrete. The concretes were produced in different compressive strength classes up to C35/45, containing fly ash and gravel aggregates with a maximum size of 16 mm. Additionally, a retarder delayed the cement hydration, to ensure a duration of up to three hours to perform the experimental tests.

Table 1: Information on the investigated concretes; abbreviations:
 BV: water reducer, VZ: Retarder, FM: superplasticizer on the basis of polycarboxylate, w/c: water-cement ratio, w/b: water-binder ratio

Concrete	Compressive strength class	Admixture	Change of consistency classes (DIN 1045-2:2008-08 [2]) in stages			w/c	w/b
			from	to	using		
1	C20/25	BV, VZ	F2	F3	water	0.7	0.65
						at F3	
2	C25/30	FM, VZ	F3	F5	FM	0.65	0.59
3	C35/45	FM, VZ	F3	F5	FM	0.52	0.49

The coordinate origin of the abscissa is defined as the time of the first sampling, after loading the drum of the ready mix truck with fresh concrete and after the initial required mixing. The first fresh concrete tests, only flow table and slump, were carried out at the ready mix concrete plant. Afterwards the ready mix truck drove to the laboratory of the Chair of Building Materials, Building Physics and Building Chemistry of the TU Darmstadt in order to take fresh concrete samples for further tests. Beside additional fresh concrete tests, rheological measurements were performed and test specimens were prepared, to determine the compressive strength and modulus of elasticity after 28 days.

Table 2 shows an overview of the investigation methods for the verification of the system Verifi. The ready mix truck itself simulated a concrete delivery tour in front of the laboratory building.

Table 2: Overview of the investigation programme

Tests to verify the System Verifi		
Method	Specification	Comment
Documentation of the determined values in the mixing drum through the System Verifi	-	Direct comparison of the results
Determination of the flow table	DIN EN 12350-5:2009-08	
Additional investigations		
Parameter	Specification	Comment
Rheological parameters	-	Further characterization of the concrete
		Correlation to fresh concrete parameter
Slump test	DIN EN 12350-2:2009-08	Checking the uniformity of concrete along the change of consistency during the tests
Density (fresh concrete test)	DIN EN 12350-6:2009-08	
Air content (fresh concrete test)	DIN EN 12350-7:2009-08	
Slump-flow test	DIN EN 12350-8:2010-12	
Compressive strength $f_{c, cube}$ (length of cube edge = 150 mm)	DIN EN 12390-3:2009-07	
Modulus of elasticity $E_{c, cyl}$ (diameter/height = 150/300 mm)	DIN 1048-5:1991-06	

By adding water or superplasticizer directly into the mixing drum the consistency was changed stepwise. Thereby the system could be investigated across the measuring range, see Figure 2. DIN 1045-2:2008-08 [2] provides a minimum mixing time of 1 min/m³ concrete and 5 minutes respectively after an addition of admixtures. Within the scope of this project, the total mixing time was 10 minutes after each dosing, by a loading volume of 6 m³ fresh concrete. Due to a minimum loading capacity of 3 m³ concrete in the mixing drum, according to the manufacturer, the total loading was reduced by 1 m³ concrete, additionally to the samplings. As a result, the operability of the system could be checked at a lower load capacity.

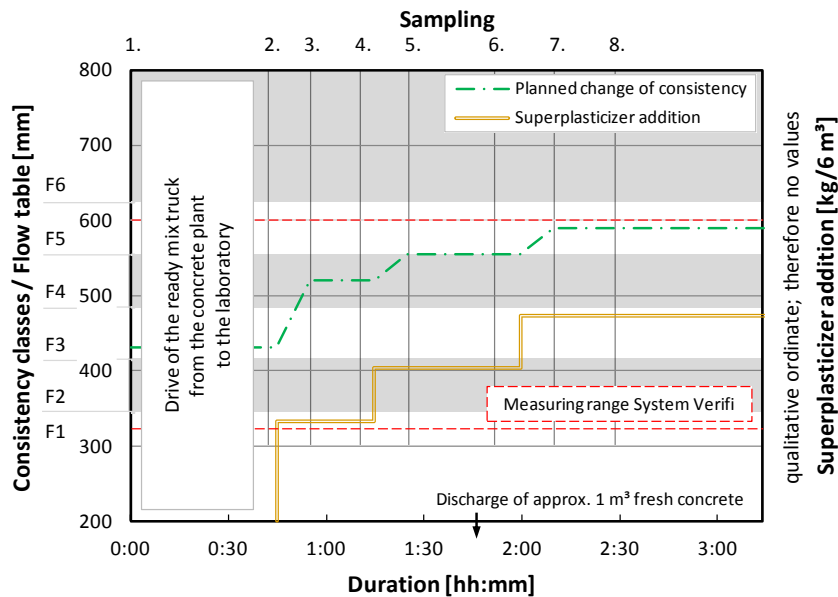

Figure 2: Test methodology: Specified change of consistency by adding superplasticizer² over the duration of up to three hours and unloading of approx. eight samplings from the ready mix truck

4. INVESTIGATIONS

4.1 Flow table test

The investigations were focused on the flow table test, with the target of a direct comparison between results determined in accordance with DIN EN 12350-5:2009-08 [1] and the identified consistency values of the system Verifi.

4.2 Rheological Measurements

The rheological measurements were carried out with the ICAR rheometer. For the identification of the parameters of viscosity as well as static and dynamic yield stress two measurement principles were applied. The objective was to compare the determined rheological parameters along the time scale of the experimental tests.

Rheological tests with a default of constant speed of 0,025 1/s and by measuring the increase of the shear stress, the static yield stress was evaluated.

The dynamic yield stress and plastic viscosity was determined by setting a first speed at 0.5 1/s, which was lowered after a pre-shearing phase of 20 seconds in total seven times over the time of the experiment (step down ramp). The torque was measured during each step for five

² The superplasticizer addition was carried out based on the initial volume of 6 m³ of the investigated concrete.

seconds, but not considering the first second of each stage. This reduces possible thixotropic effects [3] and a consistent shear history is developed. The dynamic yield stress and plastic viscosity is then determined based on the raw data and using a nonlinear analysis by applying the Reiner-Riwlin equation.

4.3 Additional investigations

The scope of the fresh concrete investigations was extended by the slump and slump-flow test. The last one came into use as soon as the scope of slump-flow test [4] has been exceeded due to a more flowable consistency. Further tests were performed to determine the fresh concrete density and the air content. Additionally hardened concrete tests were performed. The determination of the compressive strength was carried out on cubes with an edge length of 150 mm and the modulus of elasticity of cylinders (diameter/height = 150/300 mm) at concrete age of 28 days in order to characterize the concrete more comprehensively. While only the flow table and slump test were performed after the first sampling in the concrete plant, the additional tests were carried out at each sample of a batch taken from the ready mix truck located in front of the laboratory.

5. RESULTS

The focus of the investigations was to determine flow table in order to compare these parameters directly with the consistency values recorded by system Verifi. Additional investigations were carried out, especially rheological measurements, for a more comprehensive characterisation and for the identification of possible changes of concrete properties along the duration of the experimental tests.

Within this chapter main results of the project are presented. These outcomes were obtained on six consecutive work days in August 2010. The experimental tests were performed in each case mornings, with relative constant weather conditions by almost 20 °C outdoor temperature and partly cloudy to cloudy.

5.1 Flow table test

Figure 3 shows a comparison of exemplary flow table test results which were determined by the system Verifi and in accordance to [1]. Along the duration (x-coordinate) of the experimental tests the consistency or its change is presented in dependence of the superplasticizer addition. The comparison of the results for ready mix truck A indicates a good quality in identifying the consistency.

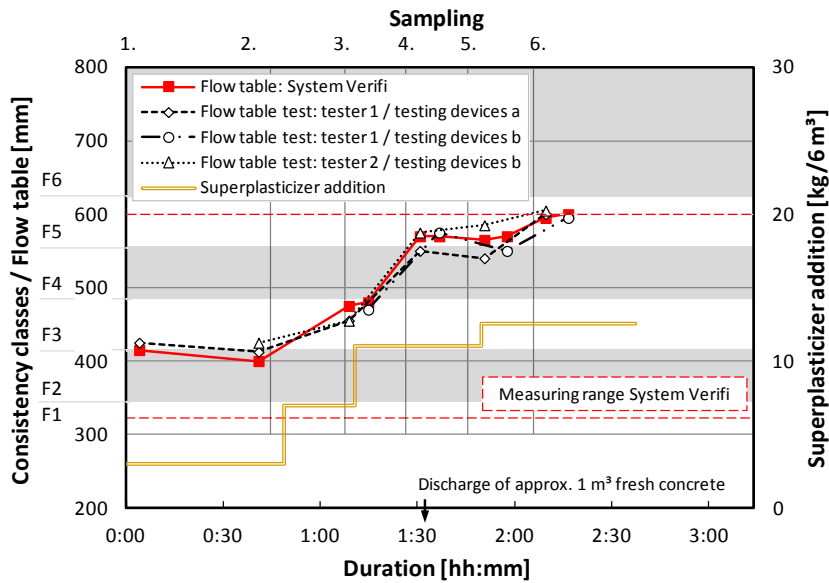

Figure 3: Comparison of the flow table values measured by the System Verifi and determined according to DIN EN 12350-5:2009-08 depending on superplasticizer² addition and duration, ready mix truck A and concrete 3

A comparison of the results for ready mix truck B is given in Figure 4. At this a deviation of the consistency values determined by the system Verifi is indicated. Since the measuring range of the system is from 320 till 600 mm, the results determined including the fresh concrete of the seventh sampling can be compared in Figure 4. When the flow table test exceeds 600 mm, system Verifi does not determine values above this limit.

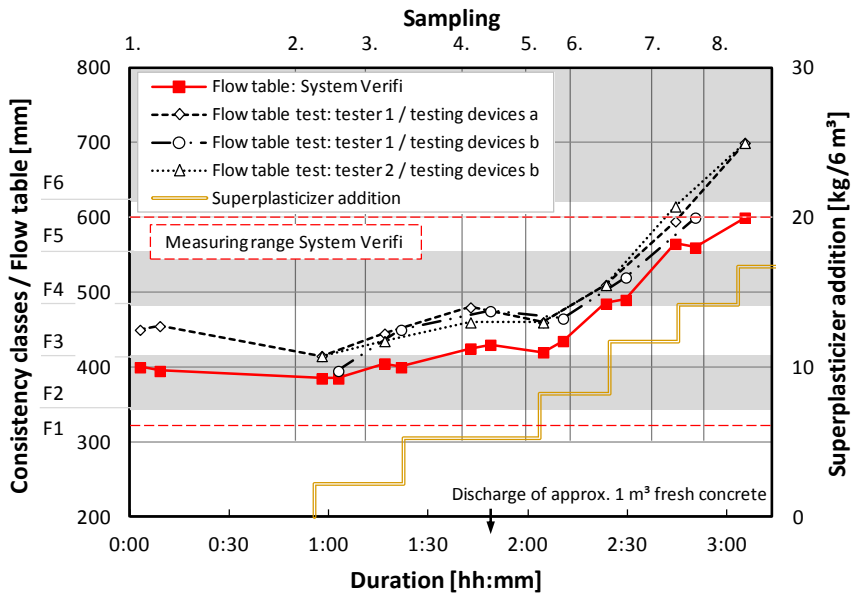

Figure 4: Comparison of the flow table values measured by the System Verifi and determined according to DIN EN 12350-5:2009-08 depending on superplasticizer² addition and duration, ready mix truck B and concrete 2

Altogether, no segregation could be observed during the performance of flow table tests with the investigated concretes and their consistencies from plastic to flowable.

The analysis of the flow table test results can be done in accordance to the precision data of DIN EN 12350-5:2009-08. Amongst reproducibility conditions and a flow table level of 555 mm is repeatability standard deviation of 32,5 mm and a repeatability value of 91 mm given [1]. Furthermore, there are specified "tolerances for target values of consistence" in DIN EN 206-1:2000. For all diameters of the flow ± 30 mm are tolerable. Additional limit deviations can be used based on the conformity criteria [5].

5.2 Rheological Measurements

Similar as in the determination of the consistency in a ready mix truck by the system Verifi, the applied torque could also be determined by rheometric measurements. Thus, rheological parameters were determined independently from the monitoring system on the truck and in addition evaluated.

In Figure 5 exemplary results of the dynamic and static yield stresses and plastic viscosity are displayed for ready mix truck B, loaded with concrete 2. These results are in dependence of the admixture addition and the duration of the tests. The calculated values of the two yield stresses tend to have a similar course. Superplasticizer was added after each sampling. Following, the fresh concrete was mixed for 10 minutes in the drum of the ready mix truck. As a result the yield stresses decreased.

A comparison of both yield stresses shows that the static yield stress is slightly higher than the dynamic yield stress. Whereat the static yield stress builds up after the mixing process is finished. In the resting state, a correspondingly high static yield stress prevents the tendency for segregation of the concrete and is thus a measure for stability of concrete. A lower dynamic yield stress on the other hand indicates a good flowability. While a low dynamic yield stress exists, a minimum viscosity is also required until the static yield stress builds up. Overall, a balance must be maintained so that both conditions can be met.

The plastic viscosity shown in Figure 5 was reduced from a relatively high value after the second sampling. This could be a result of an additional entry of mixing energy, after further admixture was added into the fresh concrete and mixed in the ready mix truck. Following a new rise of plastic viscosity is recorded after the seventh sampling.

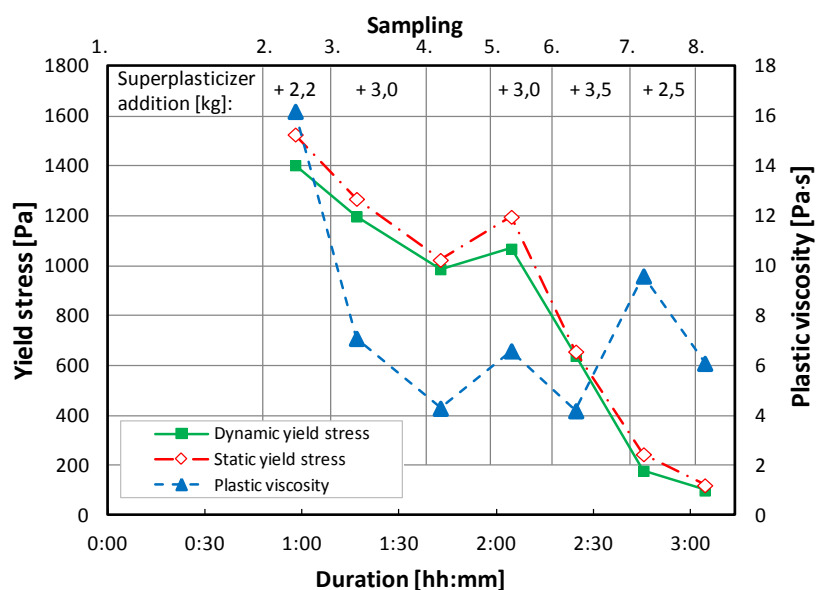

Figure 5: Results of the dynamic and static yield stress as well as plastic viscosity depending on superplasticizer² addition and duration, ready mix truck B and concrete 2

5.3 Correlation between flow table test results and yield stress

As shown in Figure 6 and 7, a correlation exists between the flow table test results and the dynamic yield stress. Besides, the obtained results proved the already documented relationship between slump and yield stress by Wallevik [6].

The illustrated regression lines in Figure 6 and 7 are based on the individual values of the flow table test according to [1]. Further, an interval with the upper and lower limit for a confidence level of 95 % is given.

The results of the system Verifi in form of the flow table values are compared with the dynamic yield stress. Figure 6 shows the results of the system for ready mix truck A and concrete 2, which are close to the regression line. The Verifi results of ready mix truck B and concrete 2 tend towards the lower confidence limit.

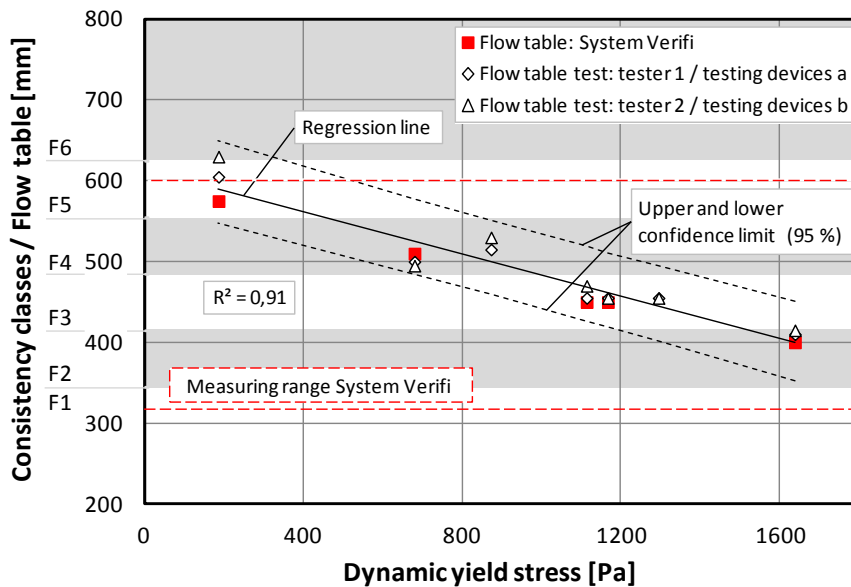

Figure 6: Correlation: Flow table and dynamic yield stress, ready mix truck A and concrete 2; regression line of the test results according to [1] and a 95 % confidence interval

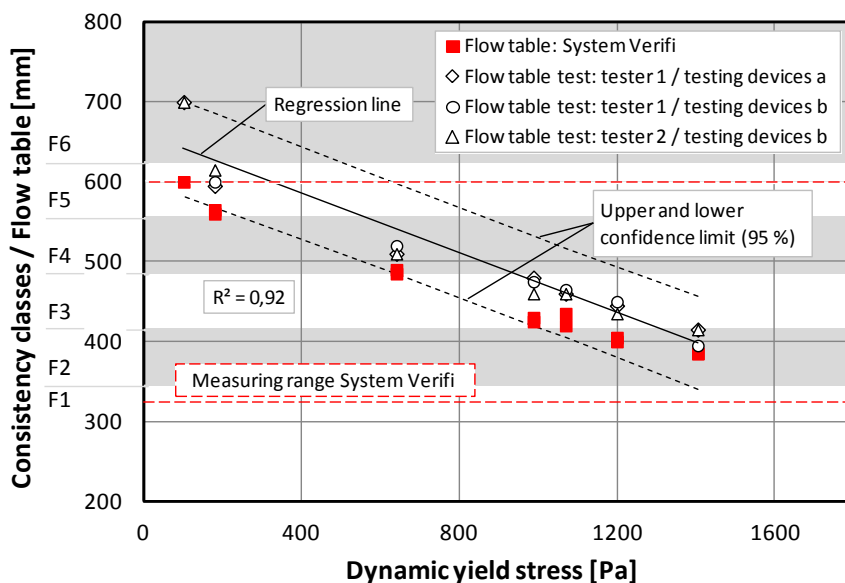

Figure 7: Correlation: Flow table and dynamic yield stress, ready mix truck B and concrete 2; regression line of the test results according to [1] and a 95 % confidence interval

5.4 Additional investigations

Additional experiments offered valuable clues about fresh and hardened concrete properties. Complementary fresh concrete tests provided information about slump, density, air content and slump flow. The compressive strength was investigated on cubes with 150 mm edge length and the elastic modulus on standard cylinders (diameter/height = 150/300 mm). The hardened concrete tests were performed at a concrete age of 28 days. The aim was to characterise the concrete extensively and to identify any undesirable changes, such as segregation of fresh concrete, increase of the air content or reduction of the compressive strength over the duration of the experimental tests while the consistency of the concrete was changed in the ready mix truck. On the basis of all test results, no significant changes or any reduction of quality were found on the investigated concrete technological properties with regard to the fresh and hardened concrete.

6. CONCLUSION

The purpose of the project was to evaluate the system Verifi determining table flow of normal strength concrete on the basis of DIN EN 12350-5:2009-08. According to the obtained findings and results a good quality for the detection of the fresh concrete consistency during transport in a ready mix truck is given. Therefore Verifi is applicable for the investigated concretes. However the calibration was identified as a significant factor influencing the quality of the calculated parameters using the system. Initial investigations suggested that the system calibration depends particularly on vehicle type and mixing drum setup type. Quantitative information on this subject requires more extensive testing.

Acknowledgment

We gratefully acknowledge the Forschungsgemeinschaft Transportbeton e. V. for funding this project and for the very good cooperation.

Literature

- [1] DIN EN 12350-5, Testing fresh concrete – Part 5: Flow table test; Beuth Verlag, Berlin, August 2009
- [2] DIN 1045-2, Concrete, reinforced and prestressed concrete structures – Part 2: Concrete - Specification, properties, production and conformity - Application rules for DIN EN 206-1; Beuth Verlag, Berlin, August 2008
- [3] ICAR Rheometer, Manual, 1st September 2008
- [4] DIN EN 12350-2, Testing fresh concrete – Part 2: Slump-test; Beuth Verlag, Berlin, August 2009
- [5] DIN EN 206-1, Concrete – Part 1: Specification, performance, production and conformity; German version EN 206-1:2000, Beuth Verlag, Berlin, July 2001 with changes A1 (10-2004) und A2 (09-2005)
- [6] WALLEVIK, J. E.: Relationship between the Bingham parameters and slump. Cement and Concrete Research, 2006, 36, 7, p. 1214-1221